

NPE Series



NPE-A and NPE-S Condensing Tankless Water Heaters

Navien makes it easy to go tankless in residential and commercial applications.



New NaviLink Wi-Fi remote control system...Now available as an add-on accessory.



NPE-Advanced

Our advanced high efficiency condensing tankless water heater technology with exclusive ComfortFlow internal pump & buffer tank



ComfortFlow®

Exclusive built-in recirculation system included on all NPE-A models

Navien ComfortFlow® was the first system to incorporate a built-in insulated buffer tank and recirculation pump. The buffer tank eliminates the "cold water sandwich" effect and issues of minimum flow rates commonly found in other tankless water heaters. The recirculation pump saves on water bills by reducing the time to get hot water. When activated, the optional ComfortFlow mode results in additional energy usage.

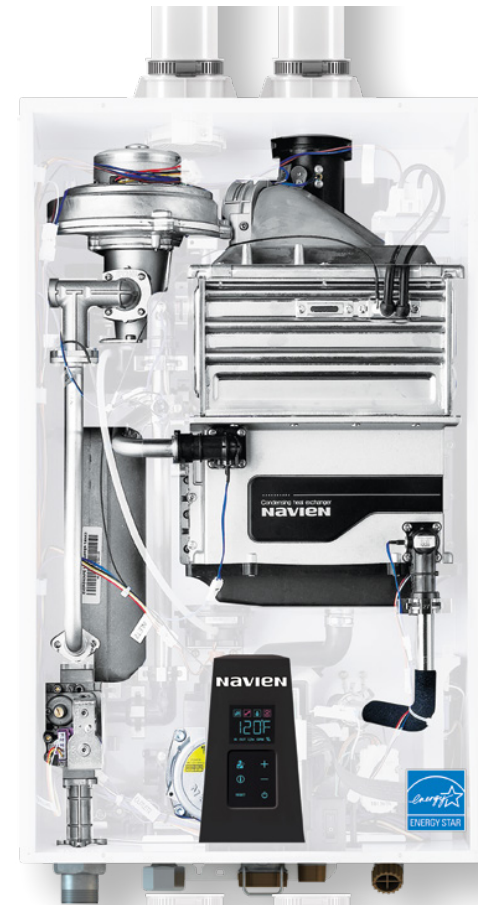

2" PVC VENTING UP TO 60 FT

1/2" GAS CAPABILITY UP TO 24 FT

CASCADE UP TO 16 UNITS

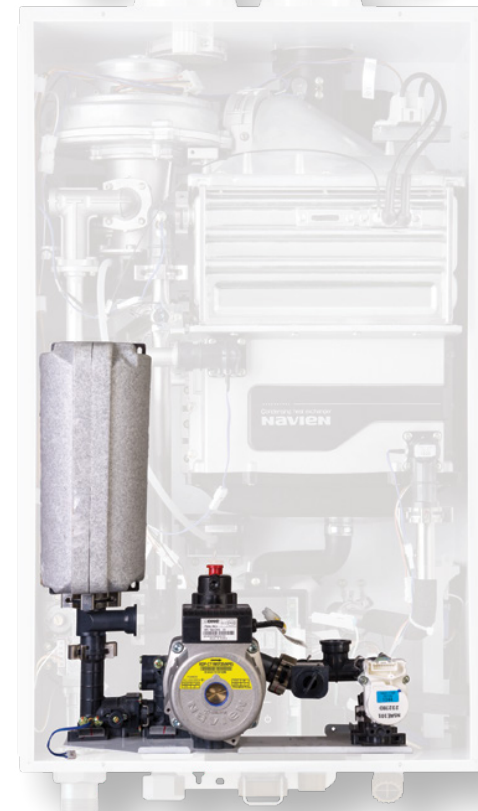

THE LEADER IN CONDENSING TECHNOLOGY

www.renoplumbingdoctor.com

(775) 852-0111

